

## **Eddy current thickness monitoring of aerospace technics coatings and constructions**

Vladimir A. SYASKO, Irina V. PILATOVA, Anton E. IVKIN

Constanta LTD, Pob 89, St-Petersburg, 198095, Russia, Phone +7 812 3722903, Fax +7 812 3722904,  
E-mail:office@constanta.ru

### **Abstract**

The distinctive feature of aerospace constructions is the big nomenclature of applied materials – alloyed and stainless steels, aluminum, copper and titanic alloys, carbon composite materials, and also a great number of their coatings – galvanic and plating metal (zinc, nickel, chromic, cadmium, gold, silver, copper, etc.), and also dielectric coatings (paint and varnish of general purpose, heat-shielding, heat resisting, anticorrosive, etc.)

In work the analysis of problems of thickness measurement of different constructions walls (in the majority the of electro conductive non-ferromagnetic materials in a range of thickness from 0,4 to 12 mm) and also their coatings (thickness of 1 micron to 150 mm) is carried out and is shown that the majority of problems of measurement can be solved with use of eddy-current phase, amplitude-phase and frequency methods.

On the basis of the analysis the structure of constructional similar eddy-current transducers is developed, the basic parities for calculation and optimization of their characteristics, and also a technique of suppression of influence of stirring parameters are resulted. The calculated and developed geometrically similar primary transducers, algorithms of their functioning and the basic technical characteristics are considered.

The developed devices with eddy-current transducers allow to organize monitoring of technics on Russian aerospace enterprises

**Keywords:** Eddy current, aerospace, coating, construction, thickness

## **1. Introduction**

The analysis of problems of measurement of a thickness of coatings and products of aerospace enterprises shows that using the eddy-current phase, the amplitude – phase and frequency methods can best solve the following problems:

- Measurement of a thickness of electroconductive not ferromagnetic products, including anisotropic with low electroconductivity:
- Sheet of aluminum alloys products, including multilayered, from 0,2 to 6 mm with electroconductivity of 14 to 30 MSm/m;
- The walls of titan and its alloys products (thickness of 0,3 to 6 mm with electroconductivity of 0,3 to 2 MSm/m);
- The walls of large-scale structures of carbon-fiber-reinforced materials and carbon - carbon materials in the thickness of 2 to 12 mm with electroconductivity of 7 to 42 MSm/m;
- Revealing of stratifications and their depth in carbon-fiber-reinforced products;
- Measurement of thickness of the electrically conductive non-ferromagnetic coatings on non-ferrous products, including small-scale (coating thickness of 2 to  $\approx$  100 microns for the electrical conductivity of coatings and base of 6 to 60 mSm / m in various combinations);
- Measurement of thickness of the conductive non-ferromagnetic coatings (coating thickness of 2 to  $\approx$  100 microns in the electrical conductivity of coatings from 6 to 60 mS / m) in the electrically conductive ferromagnetic products, including small and a large surface roughness;
- Measurement of the thickness of the ferromagnetic conductive coatings (electrolytic nickel thickness to 120 microns) on the electrically conductive ferromagnetic products, including small and large with scherohovostyu.

Consider the solution of some of the most pressing problems of measurement of the above.

## 2. Eddy current measurement of carbon fiber

In recent years in aerospace engineering has significantly increased the use of constructional carbon-fiber-reinforced materials (CFRM) with some unique characteristics, which depend on the scheme of reinforcement, the type and texture of the fiber, degree of filling in the properties of the polymer matrix (binder), compliance with manufacturing process, etc.

The block scheme of four-winding eddy current phase transducer for measuring electrical conductivity, wall thickness and searching bundles, using as a reference signal the voltage of the compensation winding is shown in Fig. 1.

Coil  $W_m$  gets sinusoidal voltage  $u_1(t)$  with frequency  $f$ . Voltage on measuring coil  $W_m$  is equal to the sum of the voltages  $\dot{U}_0$  arising in absence of a controllable product, and brought (differential) voltage  $\dot{U}_i$ , arising due the influence of a product:  $\dot{U} = \dot{U}_0 + \dot{U}_i$ . Strengthened differential (brought) voltage  $\Delta u(t)$  arrives on phase detector PD. Voltage  $u_c(t)$  from an exit of compensating coil  $W_c$  serves as a basic signal for the phase detector. Constant voltage  $U_{\square\square}$  on an exit of the filter of low frequency is proportional to difference between voltage  $u_c(t)$  and differential (brought) voltage  $\Delta u(t)$ . Balancing of coils of the transducer is made with use of the digital potentiometer  $R_1$  operated microcontroller MC. The sensitive element of the transducer for the decision of problems of measurement of conductivity and thickness of a wall is presented on fig. 2.

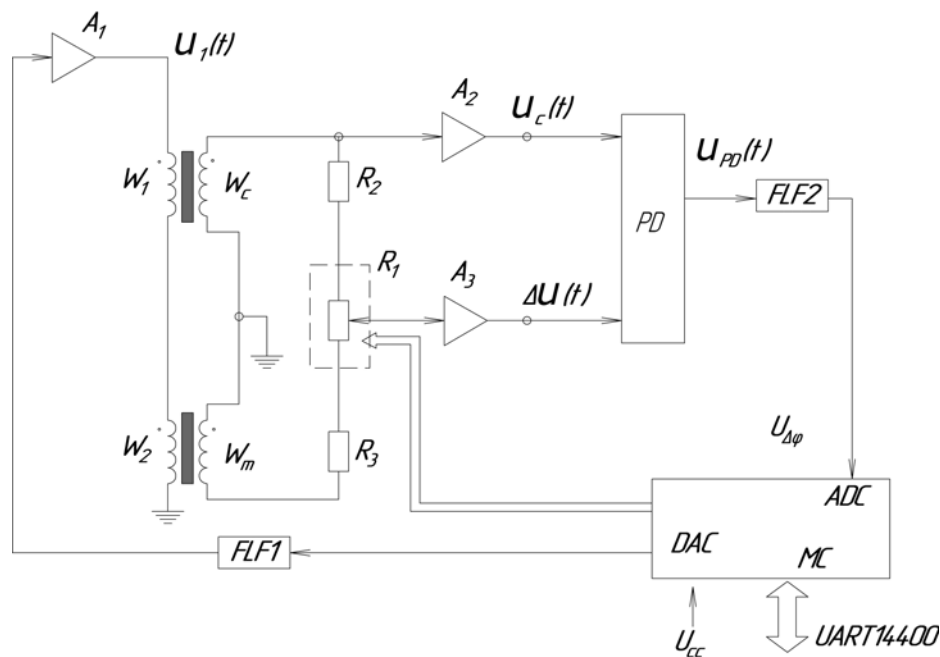

Figure 1. Block scheme of eddy current phase transducer:

$A_1$ ,  $A_3$  – amplifiers, PD – phase detector, FLF<sub>1</sub> - FLF<sub>2</sub> - low frequency filters,  $W_1$  and  $W_2$  – excitation coils,  $W_m$  and  $W_c$  – differentially connected measuring and compensating coils, MC – microcontroller,  $R_1$  – an operated digital balancing potentiometer

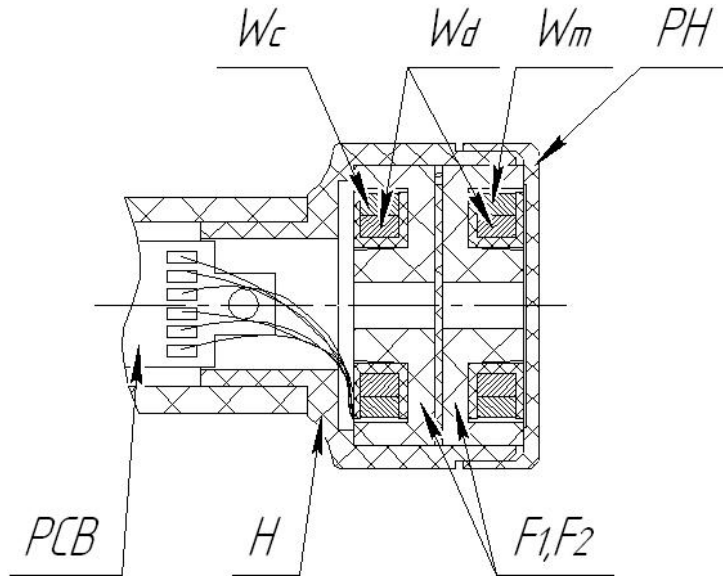

Figure 2. The sensitive element of the transducer for the decision of problems of measurement of conductivity and thickness of a wall:  $W_d$  - excitation coils,  $W_m$  and  $W_c$  - differentially connected measuring and compensating coils,  $F_1$  and  $F_2$  - ferrite cores, PH - the protective holder; H - the holder, PCB - the printed-circuit board with elements of the electric scheme

For the analysis of characteristics of the measuring transducer it is convenient to use the generalized parameter

$$\beta = R\sqrt{2\pi f\sigma_i\mu_0} \quad (1)$$

where  $R$  - equivalent radius of excitation coil;  $f$  - frequency of excitation current;  $\sigma_i$  - integrated electrical conductivity of material;  $\mu_0$  - a magnetic constant.

For maintenance of comprehensible sensitivity at measurement of conductivity  $\sigma_i$  it is necessary to choose a value of  $\beta_\sigma$  at level of an order 5... 20. Generally a depth of penetration of eddy currents  $\delta$  is equal:

$$\delta = 1/\sqrt{\pi f\sigma_i\mu_0} \quad (2)$$

For a considered problem of parities conductivity measurement the minimum admissible value of a thickness  $T_{\min} \approx 1,7\delta$ . From parities, specified above, follows that optimum value of frequency of the transducer for measurement of conductivity is equal:

$$f_{\sigma_0} \approx 2,89/(\pi\mu_0\sigma T_{\min}^2), \quad (3)$$

For maintenance specified  $\beta_\sigma$  an equivalent radius  $R$  of coil  $W_2$  for eddy current phase transducers is necessary to choose from a condition:

$$R = \beta\sqrt{2\pi f\sigma_i\mu_0} \quad (4)$$

At the analysis of characteristics of the transducer it is necessary to consider the influence of stirring parameters, such as: a backlash  $h$  between the transducer and a product, diameter of product  $d$  in a zone of measurement and its variations, roughness of a product  $R_z$ . The conducted researches of products from CFRM with different schemes of reinforcing and various parities of a reinforcing material and binding have shown that it is possible to speak about a range of integrated conductivity  $\sigma_i \approx 7 \dots 35$  kSm/m.

For products with integrated conductivity  $\sigma_i = 35$  kSm/m optimum frequencies for measurement of conductivity  $f_{\sigma_0} (T = 10 \text{ mm}) \approx 200$  kHz and  $f_{\sigma_0} (T = 2 \text{ mm}) \approx 5$  MHz. For products with integrated conductivity  $\sigma_i = 7$  kSm/m  $f_{\sigma_0} (T = 10 \text{ mm}) \approx 1$  MHz and  $f_{\sigma_0} (T = 2 \text{ mm}) \approx 25$  MHz. For cores of armored type with screen radius  $R = 6 \dots 15$  mm at calculated values of frequencies  $\beta_\sigma \approx 7$  that, basically, satisfies to conditions of maintenance of optimum sensitivity. However, a block scheme of eddy current phase transducer shown in Fig. 1 provides the top range of working frequencies at level of an order 5 MHz that corresponds to  $T_{\min} \approx 5$  mm at  $\sigma_i = 7$  kSm/m. It is mean that measurement of conductivity won't be provided in all range of supervised  $T$  and  $\sigma_i$ . In this case at  $T < 5$  mm an application of eddy current frequency method for measurement  $\sigma_i$  is possible, taking into account that it doesn't provide compensation  $h$  and  $R_z$ .

The dependence of complex relative brought voltage  $\dot{U}_i^* = \dot{U}_i / |\dot{U}_0|$  for a problem of definition of conductivity with reference to the transducer with  $R = 6$  mm and  $f \approx 5$  MHz is presented on fig. 3 (a curve 1).

The point A corresponds  $\sigma_i = 7$  kSm/m ( $\beta_\sigma \approx 3$ ), a point B corresponds  $\sigma_i = 35$  kSm/m ( $\beta_\sigma \approx 7$ ). Lines of tap 2 and 3 illustrate influence  $h$  in points of measurement A and B. For suppression of influence of a gap it is necessary to displace a point of complex relative brought voltage on air on an imaginary axis on size  $\dot{U}_{of}^*$  by electronic balancing with use of operated potentiometer  $R_1$ .

The considered transducer doesn't allow smoothly change frequency of an exciting current therefore, it is necessary in the optimum image to pick up frequencies of several transducers for overlapping of measurement ranges  $T$  and  $\sigma$ . For instance, if  $T \geq 5$  mm, it is optimal to measure the electrical conductivity by the transducer, for which  $f = 0,8$  MHz,  $R = 15$  mm, if  $T \geq 3,5$  mm, – by the transducer, for which  $f = 1,8$  MHz,  $R = 10$  mm, if  $T \geq 2$  mm – by the transducer, for which  $f = 5$  MHz,  $R = 6$  mm. To these values  $f$  and  $R$  corresponds hodograph  $\dot{U}_i^* (\sigma_i, h)$  presented on fig. 3.

For maintenance of comprehensible sensitivity at measurement  $T$ ,  $\beta_T$  should be chosen at level of an order 0,5... 2. The maximum admissible value of a measured thickness of product  $T_{\max} \approx 0,7\delta$ . From this, taking into account (1) and (2), follows that optimum values of frequency of transducers for thickness measurement is equal:

$$f_{T_0} \approx 0,49 / (\pi \mu_0 \sigma T_{\max}^2) \quad (5)$$

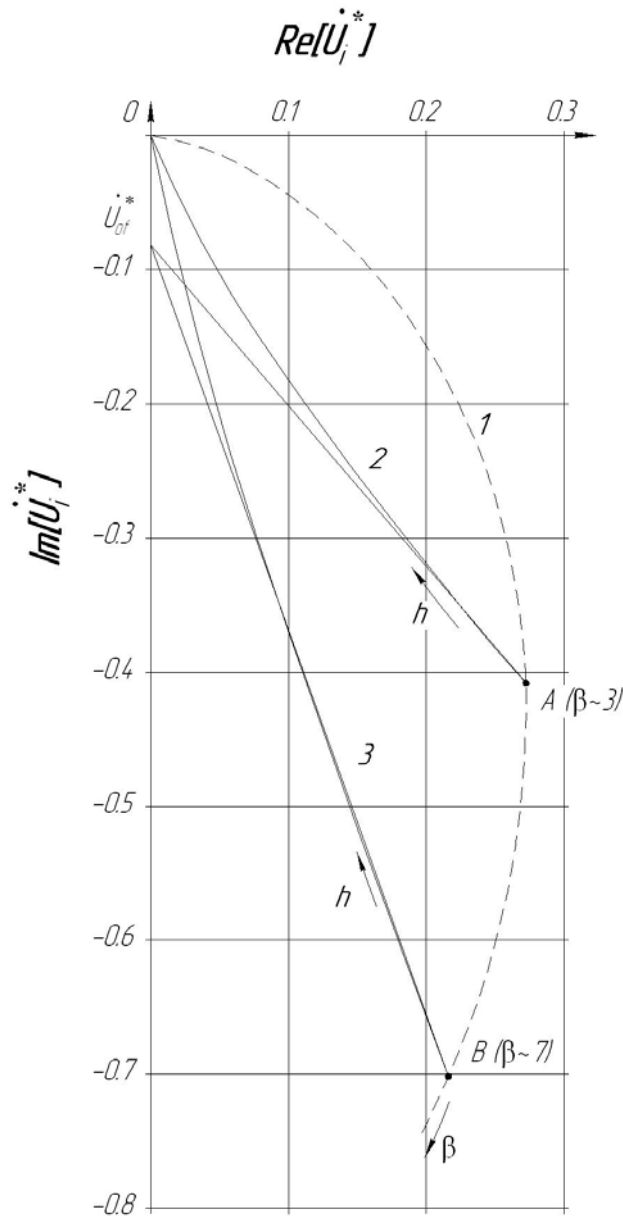

Figure 3. Dependence of complex brought voltage  $\dot{U}_i^*$  on the supervised and influencing parameters at measurement of conductivity

For products with integrated electrical conductivity  $\sigma_i = 35 \text{ kSm/m}$  optimum frequencies for boundary values  $T$  will be  $f_{T_0}(T = 10 \text{ mm}) \approx 35 \text{ kHz}$  and  $f_{T_0}(T = 2 \text{ mm}) \approx 875 \text{ kHz}$ . For products with integrated electrical conductivity  $\sigma_i = 7 \text{ kSm/m}$  -  $f_{T_0}(T = 10 \text{ mm}) = 176 \text{ kHz}$  and  $f_{T_0}(T = 2 \text{ mm}) = 4,4 \text{ MHz}$ . For cores of armored type with screen radius  $R = 6 \dots 15 \text{ mm}$  at calculated values of frequencies  $\beta_T \approx 0,6$  that, basically, satisfies to conditions of maintenance of optimal sensitivity.

On fig. 4 the calculated dependence  $\dot{U}_i^*$  from a thickness of a product for  $\sigma_i = 35 \text{ kSm/m}$  is presented at  $f = 35 \text{ kHz}$  and  $R = 15 \text{ mm}$  (a curve 1). In all range of change  $T$  from 2 to 10 mm the comprehensible sensitivity is provided, allowing to provide in normal conditions an absolute error of measurement at level  $\pm 0,01 T$ . However change of specified above stirring parameters will cause an additional error of measurement.

The line of tap 3 illustrates the influence of  $h$  in a point of measurement B. Measurement of a gap up to 0,3 mm will cause an additional error of measurement of an order 0,1  $T$ . For suppression of influence of a gap (and also equivalent to our gap  $R_z$  and  $d$ ) it is necessary to displace electronic balancing with use of operated potentiometer  $R_1$  a point of complex relative brought voltage on air on an imaginary axis on size  $\dot{U}_{of}^*$ , corresponding to a range of measurement  $T$ .

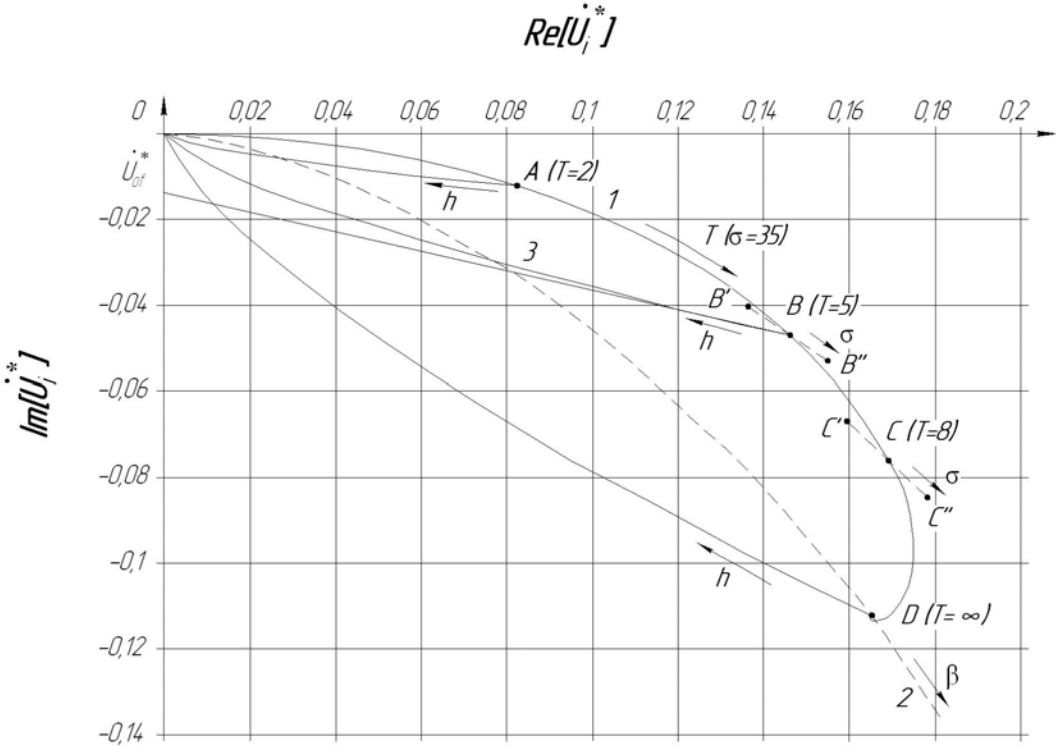

Figure 4. Dependence of complex brought voltage  $\dot{U}_{of}^*$  on the supervised and influencing parameters at measurements of a thickness of a product

Lines B'BB" and C'CC" illustrate the influence of variations of electrical conductivity of products corresponding to variations of  $\sigma_i$  from 32 to 38 kSm/m ( $\pm 10\%$  from rating value), depending on a measurement range and showing that the additional error of measurement can reach the value  $\pm (0,1 \dots 0,15) T$ .

For other values  $\sigma_i$  hodographs  $\dot{U}_{of}^*(T)$  have similar character (for example, at  $\sigma_i = 7$  kSm/m for reception of similar dependences of measurement it is necessary to spend at  $f \approx 176$  kHz and  $R = 15$  mm).

Measurement  $\sigma_i$  according to the described above allows suppress the influence of conductivity deviation on the result of measurement of  $T$ . Thus the measurement error  $\Delta T < \pm (0,01 \dots 0,03)T$ , depending on change of conductivity is provided.

For thickness measurement it is possible to use three transducers ( 1 -  $f = 35$  kHz,  $R = 15$  mm; 2 -  $f = 176$  kHz,  $R = 19$  mm; 3 -  $f = 875$  kHz,  $R = 6$  mm)

The scheme of coils of a sensitive element of the transducer for revealing of internal stratifications is presented on fig. 5.

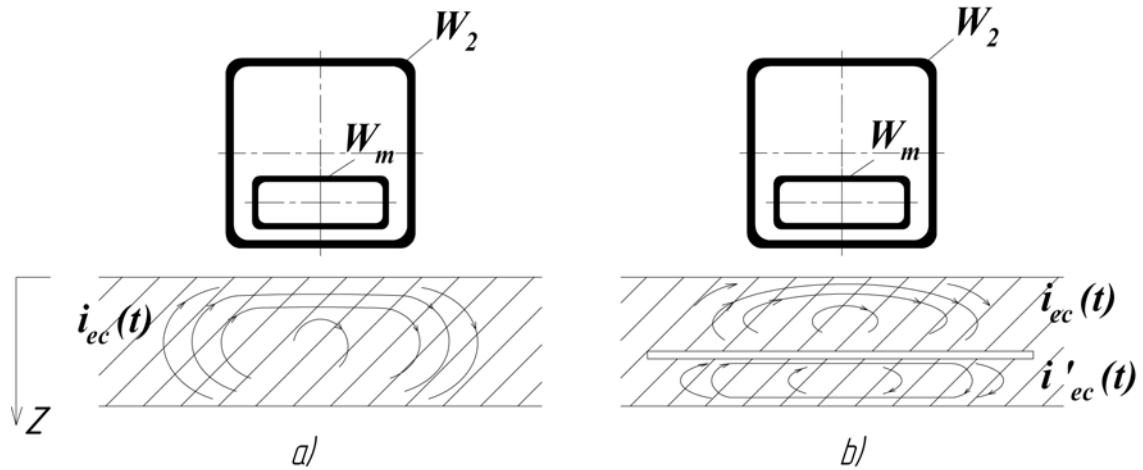

Figure 5. A sensitive element of the transducer for revealing of internal stratifications in a product and measuring of its depth  $Z$ :  $W_2$  – an excitation coil,  $W_m$  – a measuring coil. A picture of distribution of eddy currents in a plane of coils:  $a$  – without stratification,  $b$  – at stratification.

The square coil of excitation  $W_2$  of one of the parties is established on a product and creates a eddy current  $i_{ec}(t)$  (fig. 5,  $a$ ). Measuring coil  $W_m$  is in a plane of coil  $W_2$  (coils  $W_1$  and  $W_c$ , placed on removal from a product, conditionally aren't shown).  $\dot{U}_i$  on measuring coil  $W_m$  will depend, including, from presence of the stratifications which sizes are comparable to the size of a zone of control of a sensitive element. Approximately it is possible to consider the sizes of a zone of control of an order  $2L \times 2L$  where  $L$  – length of the party of coil  $W_2$ . While scanning the surface the transducer will cross the stratification comparable in the sizes with its zone of control, a picture of eddy currents there will be two contours of eddy currents in each layer of product (fig. 5,  $b$ ) that will cause changes of  $\dot{U}_i$  (reduction of amplitude and changing of  $\Delta\varphi$ ).

As the generalized parameter for the given transducer we will accept the size

$$\beta_z = L \sqrt{2\pi f \sigma_i \mu_0} \quad (6)$$

For maintenance of comprehensible sensitivity at control of stratifications the size  $\beta_z$  should be chosen at level of an order 0,5... 2. The maximum thickness of controllable products gets out of condition  $T_{\max} \approx 1,4\delta$ . From this, taking into account (1) and (2), follows that optimum values of frequency of transducers for control of stratifications equal:

$$f_{T_0} \approx 4/(\pi \mu_0 \sigma_i T_{\max}^2) \quad (7)$$

For products with integrated electrical conductivity  $\sigma_i = 35$  kSm/m optimum frequencies for boundary values  $T$  will be  $f_{T_0}(T = 10 \text{ mm}) \approx 140$  kHz and  $f_{T_0}(T = 2 \text{ mm}) \approx 1,4$  MHz.. For products with integrated electrical conductivity  $\sigma_i = 7$  kSm/m -  $f_{T_0}(T = 10 \text{ mm}) = 704$  kHz and  $f_{T_0}(T = 2 \text{ mm}) = 17,5$  MHz. For transducers with  $L = 6 \dots 15$  mm at calculated values of frequencies  $\beta_z \approx 1,4 \dots 3$  that, basically, satisfies to conditions of maintenance of optimum sensitivity.

On fig. 6 (the curve 1) the dependence  $\dot{U}_i^*$  on a thickness of a product with conductivity  $\sigma_i =$

35 kSm/m for the transducer with parameters  $f \approx 0,9$  MHz and  $L = 15$  mm is presented. Curve 2 - calculated dependence  $\dot{U}_i^*$  on stratification position on depth  $Z$  for a product in the maximum thickness 3,6 mm. At a thickness of a layer of CFRM of 0,6 mm in all range of change  $Z$  from 0,6 to 3 mm the comprehensible sensitivity allowing confidently to reveal stratification (and depth  $Z$ ) at specified above deviation  $\sigma_i$  is provided. For suppression of influence of a gap (and also equivalent to our gap  $R_z$  and  $d$ ) it is necessary to displace electronic balancing with use of operated potentiometer  $R_1$  a point of complex relative brought voltage on air on an imaginary axis on size  $\dot{U}_{of}^*$ , corresponding to a range of measurement  $T$  (as similarly problem of thickness measurement of a product).

For other values  $\sigma_i$  and  $T$  hodographs, calculated in accordance with parameters defined on (6) and (7), have similar character with corresponding scaling of parameters.

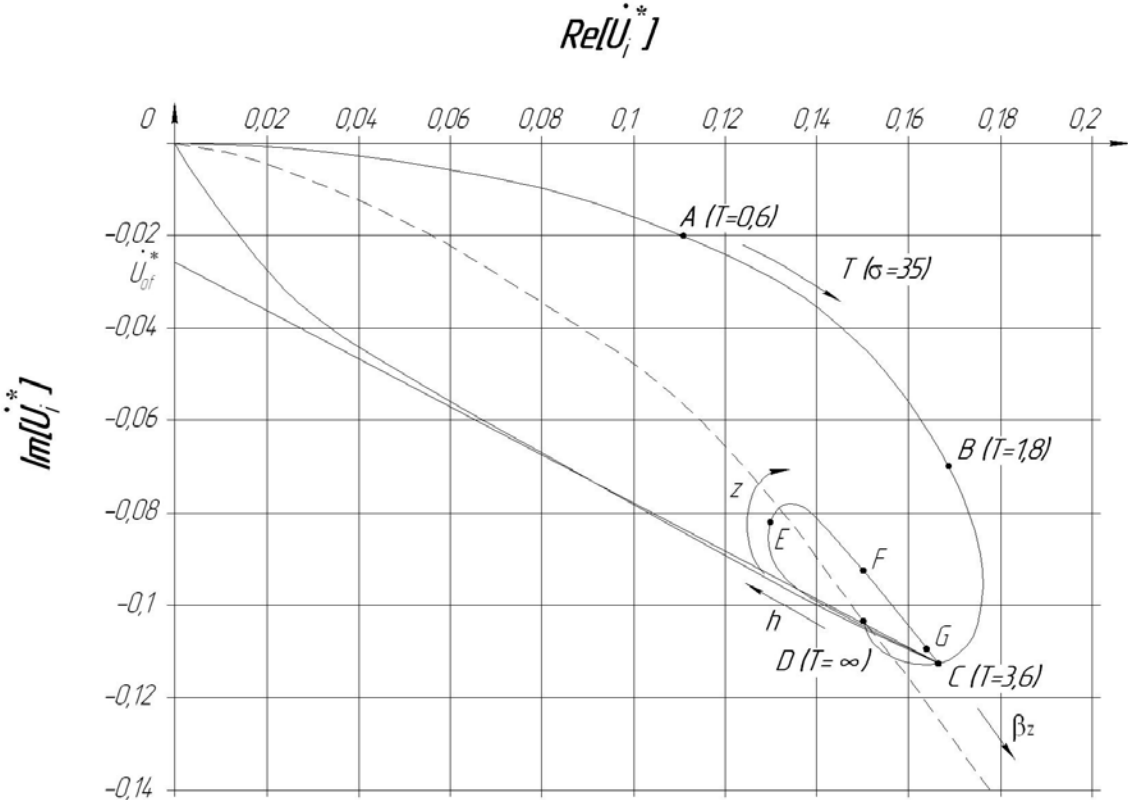

Figure 6. Dependence of complex brought voltage  $\dot{U}_i^*$  from depth of stratifications  $Z$  for a product with parameters  $T = 3,6$  mm,  $\sigma_i = 35$  kSm/m (E:  $Z = 0,6$  mm, F:  $Z = 1,8$  mm, G:  $Z = 3$  mm ))

### 3. Eddy current measurement of coatings

An important problem is measurement of a thickness of electroconductive not ferromagnetic coverings on the electroconductive bases in the field of small thickness. The decision of the given problem is characterized by considerable methodical difficulties. In particular, at  $\sigma_c \leq \sigma_b$  and  $\sigma_c \ll \sigma_b$  character of hodograph of complex brought voltage  $\dot{U}_i^*$  at a variation of a thickness of a coating is close to its change corresponding to a variation of a backlash. We will consider the decision of the given problem of measurement on an example of alloys of tin. Alloys of tin with bismuth, lead, zinc, cobalt and cadmium are widely applied to a covering of products from copper and its alloys. The range of thickness of coatings makes



from 0,5 to 21 microns. Electroconductivity of tin alloys  $\sigma_c$  lies in a range from  $\sim 6$  to  $\sim 9,5$  MSm/m, and the bases  $\sigma_b$  from  $\sim 16$  to  $\sim 60$  MSm/m. Products can be as large-sized and small-sized (a zone of measurement in diameter 2. . 5 mm at the minimum thickness of a wall to 0,3 mm), including with a rough surface (to  $R_z \approx 5... 15$  microns). The object of control represents electroconductive not ferromagnetic coating in the thickness  $T_c$  and electroconductivity  $\sigma_c$  on not ferromagnetic electroconductive base electroconductivity  $\sigma_b$ . It is possible to speak about some integrated value electroconductivity  $\sigma_z$  object of control in volume of distribution of the eddy-current, changing depending on a thickness of covering  $T_c$ .

Sensitivity of eddy-current phase method depends on parameters of controllable object:  $T_c$ ,  $\sigma_c$ ,  $\sigma_b$  and geometrical characteristics of the base and a covering (diameter  $d$ , roughnesses  $R_z$ , etc.), and  $h$ . A number of devices is developed for measurement of a thickness of electroconductive not ferromagnetic coatings on the electroconductive not ferromagnetic bases provided that relative coatings electroconductivity  $\alpha = \sigma_c / \sigma_b$  about  $\approx 6... 30$  (for example, copper on noncorrosive steel, silver on a brass). For problems of control of a thickness of coatings from tin alloys  $\alpha \approx 0,11... 0,55$ , that imposes essential restrictions on application eddy-current phase method because of total absence of sensitivity in the field of thickness of coatings to 20 microns. We will consider application possibility eddy-current amplitude - phase method for the decision of these problems of measurement.

Structural three-winding transformer circuit eddy current amplitude - phase transducer used as the reference signal voltage on the compensating winding, is shown in Fig. 7. The transducer is made in a small cylindrical holder, attached to the electronic control unit cable, which is fed by the supply voltage and organized communication channel UART14400 (Fig. 8) for communication with the block processing and presentation of results.

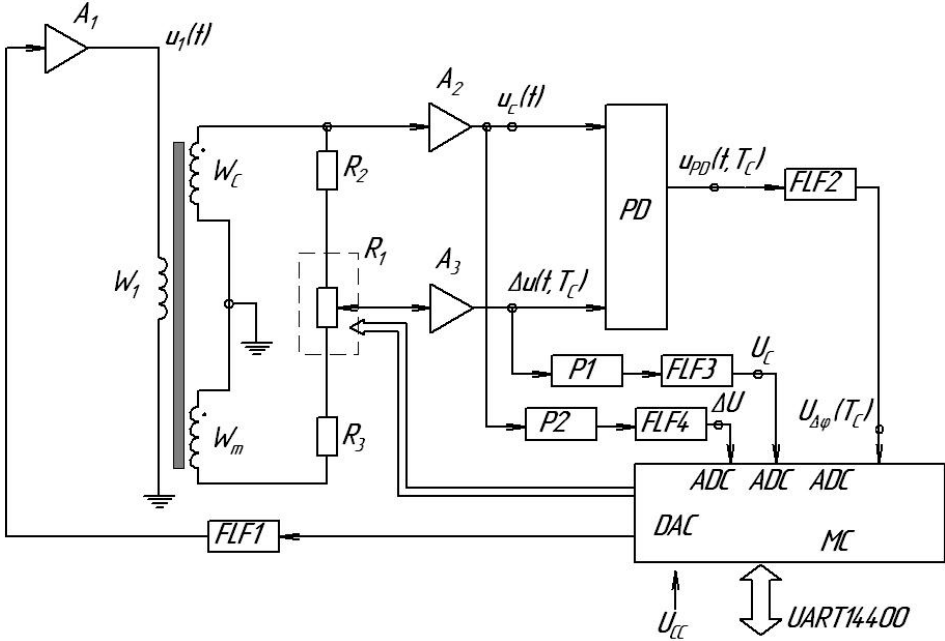

Figure 7. Structural three-winding transformer circuit eddy current amplitude - phase transducer:  $A_1 - A_3$  – amplifiers, PD – phase detector, FLF<sub>1</sub> – FLF<sub>4</sub> – low frequency filters,  $W_1$  – excitation coils,  $W_c$  и  $W_m$  – differentially connected measuring and compensating coils, P1 и P2 – peak detectors, MC – microcontroller,  $R_1$  – an operated digital balancing potentiometer

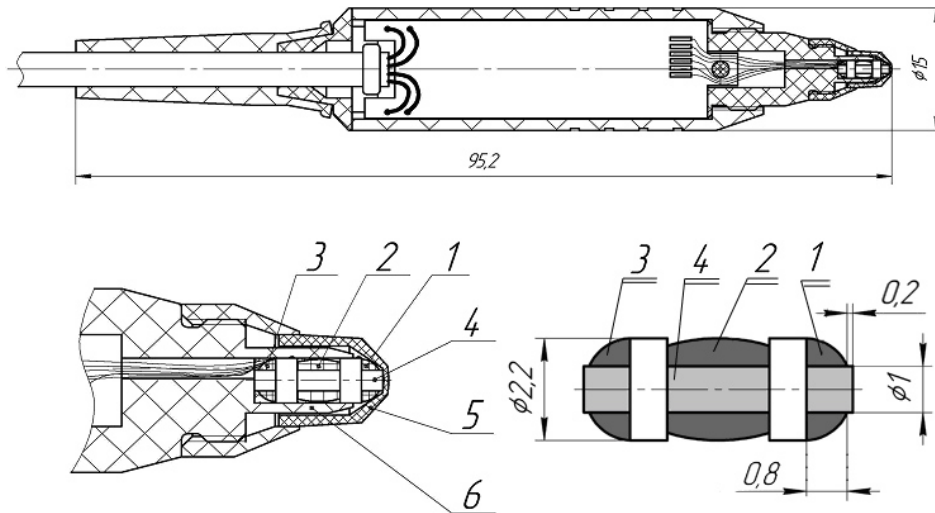

Figure 8. Consignment amplitude - phase transducer with a miniature sensor and removable protective cap: 1 - Measuring  $W_m$ , 2 - exciting  $W_1$  and 3 - compensating winding  $W_c$ , 4 - ferrite core, 5 - cap 6 - housing

The sensing element is close to the minimum technologically achievable dimensions. The ferrite core is protected from abrasion removable protective cap. The elements of an electronic circuit arranged on the printed circuit board also established inside the transducer .

Constant voltage  $U_{\Delta\varphi}$  at the output of the filter is proportional to the phase difference  $\Delta\varphi$  between the voltage  $u_c(t)$  and difference (the introduced) voltage  $\Delta u(t, T_c)$ . Constant voltage  $U_c$  and  $\Delta U$  are directly proportional to the voltage amplitude  $u_c(t)$  and  $\Delta u(t, T_c)$ . Balancing of winding is made with a digital potentiometer controlled by a microcontroller.

The maximum frequency of the excitation current  $f_{\max} = 1,8$  MHz, the error of measuring the phase difference less than  $\pm 0,05^0$ , the amplitudes of the voltage measurement error not exceeding  $\pm 0,1$  mV. To calculate the parameters of the transmitter is convenient to use the generalized parameter  $\beta$ .

The design of the sensor shown in Fig. 8, at the specified diameter of the ferrite core provides the equivalent radius of the winding  $R \approx 1,5$  mm.

The variation of  $T_c$  would lead to a change  $\sigma_z$  and, respectively,  $\beta$ . To ensure an acceptable sensitivity value  $\beta$  ( $\sigma_c$ ) should be selected at about 5 ... 30. In accordance with ISO 21 968 range measurements  $T_{\max} = (0,6 \dots 0,8)\delta$ , and the minimum permissible thickness of the base  $T_{\min} = 2,5\delta$ . From the above relations imply that the optimal value of the frequency converter  $f_{\text{opt}}$  is:

$$f_{\text{opt}} \approx (0,36 \dots 0,64)/(\pi\mu_0\sigma_c T_{\text{pmax}}^2) \quad (5)$$

To ensure optimal  $\beta$  value of the equivalent radius  $R$  winding  $W_1$  for eddy current phase converter must be chosen from the condition (3).

In analyzing the characteristics of the transducer should consider the impact of nuisance parameters:

- The gap  $h$  between the transducer and the surface;

- The diameter  $d$  of the base in the area of measurement and its variation;
- Roughness  $R_z$  surface of the product;
- Variations of the base and the electrical conductivity of the coating.

Boundary-value problems of measurement are as follows:

- 1) tin - lead /brass ( $\sigma_c / \sigma_b \sim 6,5 \text{ MSm}/16, 5 \text{ mS /m}$ );
- 2) tin - lead /copper ( $\sigma_c / \sigma_b \sim 6,5 \text{ MSm}/59 \text{ mS /m}$ ).

Shown in Fig. 8 transducer provides a maximum frequency of excitation  $f = 1,8 \text{ MHz}$ . For the materials in question the depth of penetration of eddy-currents will be as follows: for an alloy of tin - lead  $\delta_t \approx 133 \text{ microns}$ , for brass  $\delta_b \approx 90 \text{ microns}$  for copper  $\delta_{cu} \approx 45 \text{ microns}$ . Accordingly, the generalized parameters have the values:  $\beta_t \approx 14$ ,  $\beta_b \approx 22$ ,  $\beta_{cu} \approx 42$ . Is possible to take the radii of the coil equal to the radius of the ferrite core.

In Fig. 9 shows the computed dependence of the complex relative stress contributed  $\dot{U}_i^*$  to the boundary value problem tin - lead/copper (curve 2). In the section A-B in the range of  $T_c \approx 0 \dots 15 \text{ microns}$   $\Delta\varphi$  virtually unchanged, and the hodograph  $\dot{U}_i^*(T_c)$  coincides with the line of withdrawal 1. In the section C-D transducer sensitivity  $\Delta(\Delta\varphi)/\Delta T_c$  taking into account the error of measuring the phase difference allows the measurement of  $T_c$  with an absolute error at  $\pm (1 \dots 1.5) \text{ microns}$ .

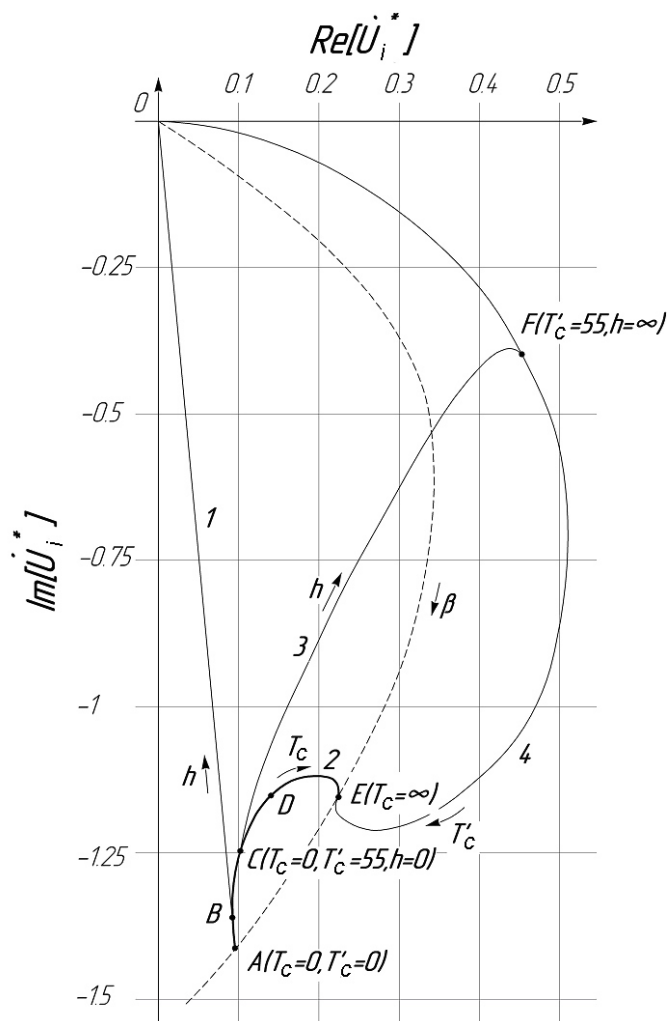

Figure 9. The dependence of the integrated stress contributed  $\dot{U}_i^*$  of the measured and influencing parameters.

To enable the measurement of thin coatings to move the start point of reference, are suitable  $T_c = 0$  in section C-D curve 2. This can be achieved by introducing "puck distance" from the material corresponding to or near the electrical conductivity covering material (eg, an alloy of tin - lead), a thickness of about  $T_c = 15 \dots 60$  microns, between the ferrite and the coating. In this case, a change  $T_c$  from zero to  $T_{cmax}$  hodograph  $\dot{U}_{*i}(T_c)$  is between points C-E. Drainage line 3 ( $T_c = 0$ ) will connect the point C with point F on curve 5 - hodograph  $\dot{U}_{*i}(T_c', h = \infty)$ .

In Fig. 10 shows the dependence  $\Delta\varphi(T_c)$  for different values of  $T_c'$ , confirming the above stated

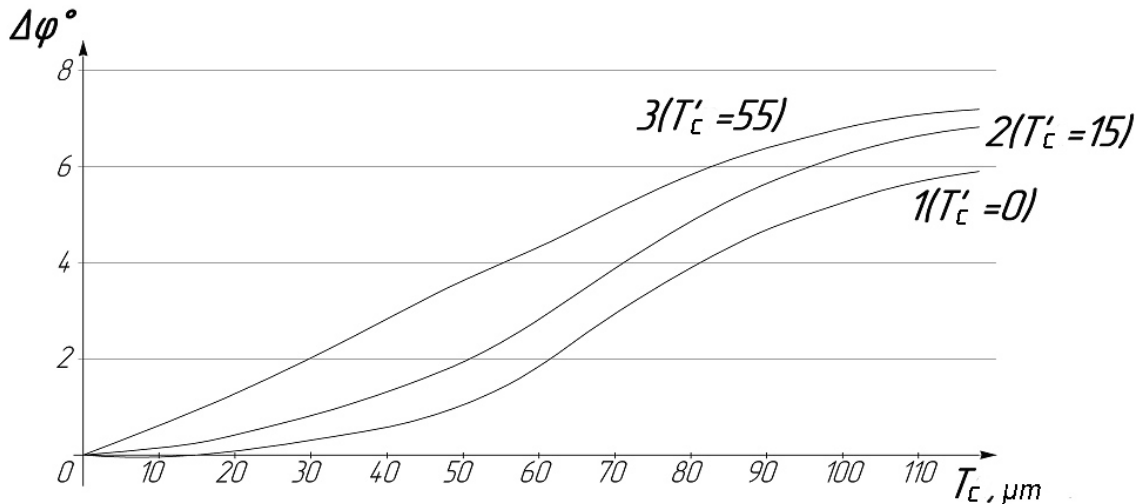

Figure 10. Dependence of the phase difference voltage on the thickness of tin – lead coatings on copper: 1 - for the standard transducer, 2 and 3 - to drive with "puck distance" a thickness of 15 microns and 55 microns, respectively

For the problem of tin-lead/brass dependence are similar. To eliminate the dead zone should be selected  $T_c = 10 \dots 40$  microns, but the sensitivity of  $\Delta(\Delta\varphi)/\Delta T_c$  in the measurement zone is approximately two times lower, which would lead to an increase in measurement error. Distance washer diameter of about 3 microns, repeating profile replacement bearing surface of the protective cap should be glued to its outer surface (fig. 8, pos. 5). The main nuisance parameters, the measurements are the foundation surface roughness  $R_z$ , and the diameter  $d$  (curvature), as well as their variation. These parameters can be associated with equivalent clearance  $h'$  between the supporting surface and the transducer surface. Thus,  $d = 25$  mm corresponds to  $h' \approx 40$  microns,  $d = 10$  mm corresponds to  $h' \approx 100$  microns.

For the detuning from the influence of  $h$  (hence, the influence of variations in  $d$  and  $R_z$ ) measurements characteristic of the transducer calibration should be a family dependency  $U_{\Delta\varphi}(T_c, h)$  and  $\Delta U(T_c, h)$ , removed on the measures the thickness  $T_c$  coating deposited on the base model, for several values of gap  $h$ . Exemplary bases must be identical or close to the base material of the electrical conductivity of controlled products. The calibration characteristic corresponds to that shown in Fig. 11 grid hodograph  $\dot{U}_{*i}(T_c, h)$  for a fixed thickness washer  $T_c'$  (or similar effect on the puck out of thick stainless steel  $T_c'$ ). Calibration characteristics should be stored in the nonvolatile memory of the transducer.

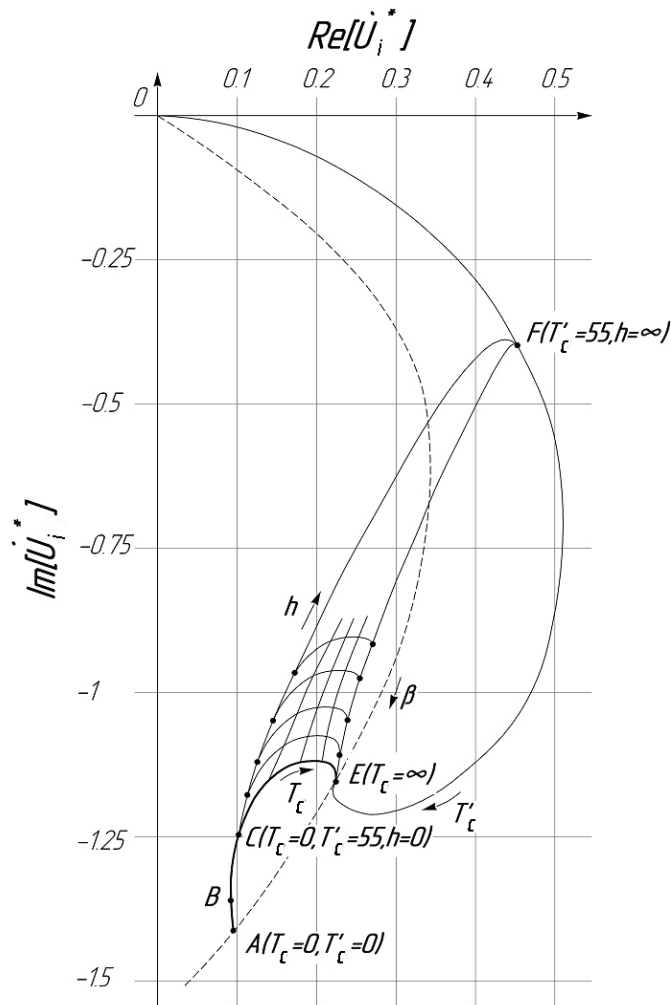

Figure 11. Grid hodograph  $\dot{U}_i^*(T_c, h)$

Calibration of the instrument (if any) is the installation procedure using a set of sensitivity measures the thickness of coating / base and setting zero on a sample of the actual product without coating. Calibration can be performed also on samples of products. To do this, you must first make a sample thickness of the coating on the product or on a sample - the witness. Similarly, we can calculate the parameters of transducers for other tasks measuring electrically conductive non-ferromagnetic coatings on ferromagnetic bases.

#### 4. Conclusions

On the basis of the calculations, a series of eddy current probes for solving the problems of measurement of wall thickness product of conductive non-ferromagnetic materials, as well as the thickness of the protective metal coatings for various purposes on products from the ferro- and non-ferromagnetic electrically conductive material. Devices K5 and K6 with a set of transducers designed and certified transducers are used in aircraft and missile enterprises to monitor products in the manufacturing process and operation.